

# The FRG's role is to do the following:

**1.** Stabilize site to limit environmental damage that could have impacted community. ✓ Completed

**2.** Develop Remedial Action Plans (RAPs) for water and solids abandoned by AltEn, submit to Nebraska Department of Environment and Energy (NDEE) for approval. 
 ✓ Water RAP approved 2022  
 ⌚ Water RAP implementation underway  
 ⌚ Solids RAP recommendation development in process

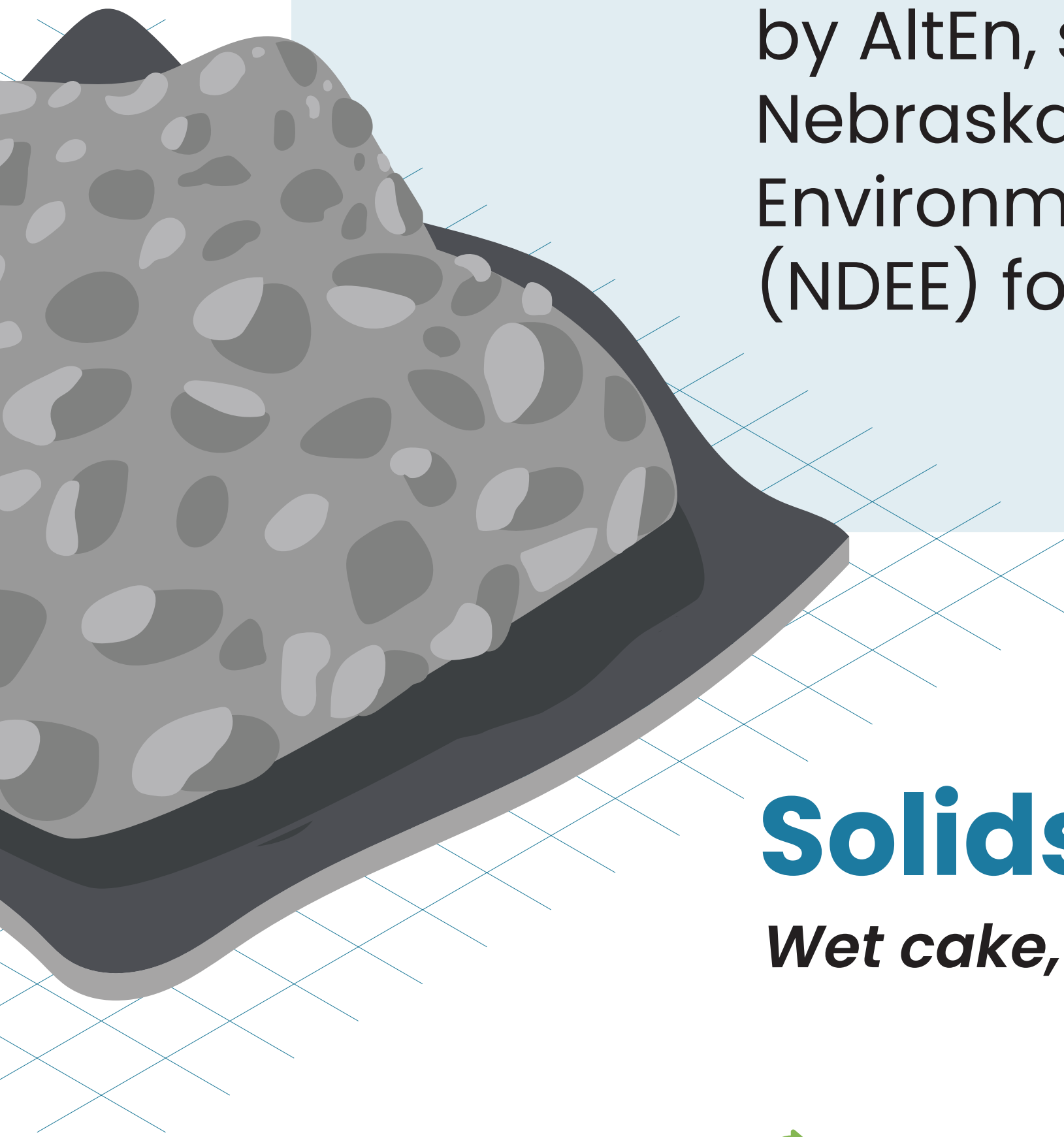

## Solids

*Wet cake, lagoon sludge, debris and leftover unused seed*

⌚ FRG is developing a RAP recommendation for the on-site solids and continues to investigate remediation options for the wet cake materials to NDEE

*The wet cake is a non-hazardous waste, but it can smell and create dust if not managed carefully.*

⌚ FRG is analyzing an approach to remediating the wet cake by solidifying and transporting it to a landfill permitted for this use

⌚ Pilot Project is being implemented to determine if this approach is viable

✓ WM has removed all non-wet-cake debris (nearly 1,600 tons)

⌚ Covanta began removing unused seed in August 2023, a process that will take 4 - 5 months to complete



For more information, please visit [alteninfo.com](https://alteninfo.com)

**NDEE has two online sites with information about the AltEn site situation:**

1. NDEE public information portal - <http://dee.ne.gov/Press.nsf/pages/AltEn>

2. NDEE public records - <https://ecmp.nebraska.gov/publicaccess/index.html?MyQueryID=340>  
 Enter "84069" in the "DEQ Facility Number" field to access AltEn records

# Water

## *Wastewater from ethanol production and stormwater*

- ✓ Sept. 12, 2022 – FRG submitted Water RAP recommendation to NDEE for approval, worked with the agency on its proposed updates to that plan
- ✓ Nov. 10, 2022 – NDEE proposed approving Revised Water RAP and solicited written public comments
- ✓ Dec. 14, 2022 – NDEE hosted public hearing and approved FRG’s RAP for water stored at the site
- 🔄 Currently: FRG implementing Water RAP
  - ✓ More than 49 million gallons of process water had been treated by end of 2022 – 31 million gallons of which had been applied to local farms as a beneficial nutrient
  - 🔄 100 million gallons (estimated) remains to be treated, plus storm water that may accumulate
- ✓ August 2023 – New onsite water treatment facility operational

### **Water RAP recommends:**

- 🔄 Treating the untreated water and the stormwater that accumulates within the lagoons and pond during the remedial action period
- 🔄 Managing the treated water through land application
- 🔄 Water RAP includes a summary of alternatives considered, the proposed remedial action, potential pre-design investigations, and the anticipated schedule



For more information, please visit [alteninfo.com](http://alteninfo.com)

**NDEE has two online sites with information about the AltEn site situation:**

1. NDEE public information portal – <http://dee.ne.gov/Press.nsf/pages/AltEn>

2. NDEE public records – <https://ecmp.nebraska.gov/publicaccess/index.html?MyQueryID=340>  
Enter “84069” in the “DEQ Facility Number” field to access AltEn records

# We're starting a pilot project

## Removing some of the wet cake from the AltEn site to inform future recommendations

The FRG has begun a Solid Waste Pilot Project to test the feasibility of removing non-hazardous wet cake from the AltEn site and placing it in a landfill. The Pilot Project consists of wet cake solidification and transporting up to 24,000 tons of wet cake at a rate of up to six trucks an hour, Monday through Friday, from 6 a.m. to 4:30 p.m. beginning in late September.

The wet cake is a **non-hazardous waste**, but it can smell and create dust if not managed carefully.

Best practices regarding storm water, dust, odors, air quality and road safety will be used during the Pilot Project. Transportation will start at a low rate and ramp up to full production within the first two weeks. Actual rates may vary, depending on what we learn, new data we collect, the weather and other factors during the Pilot Project.

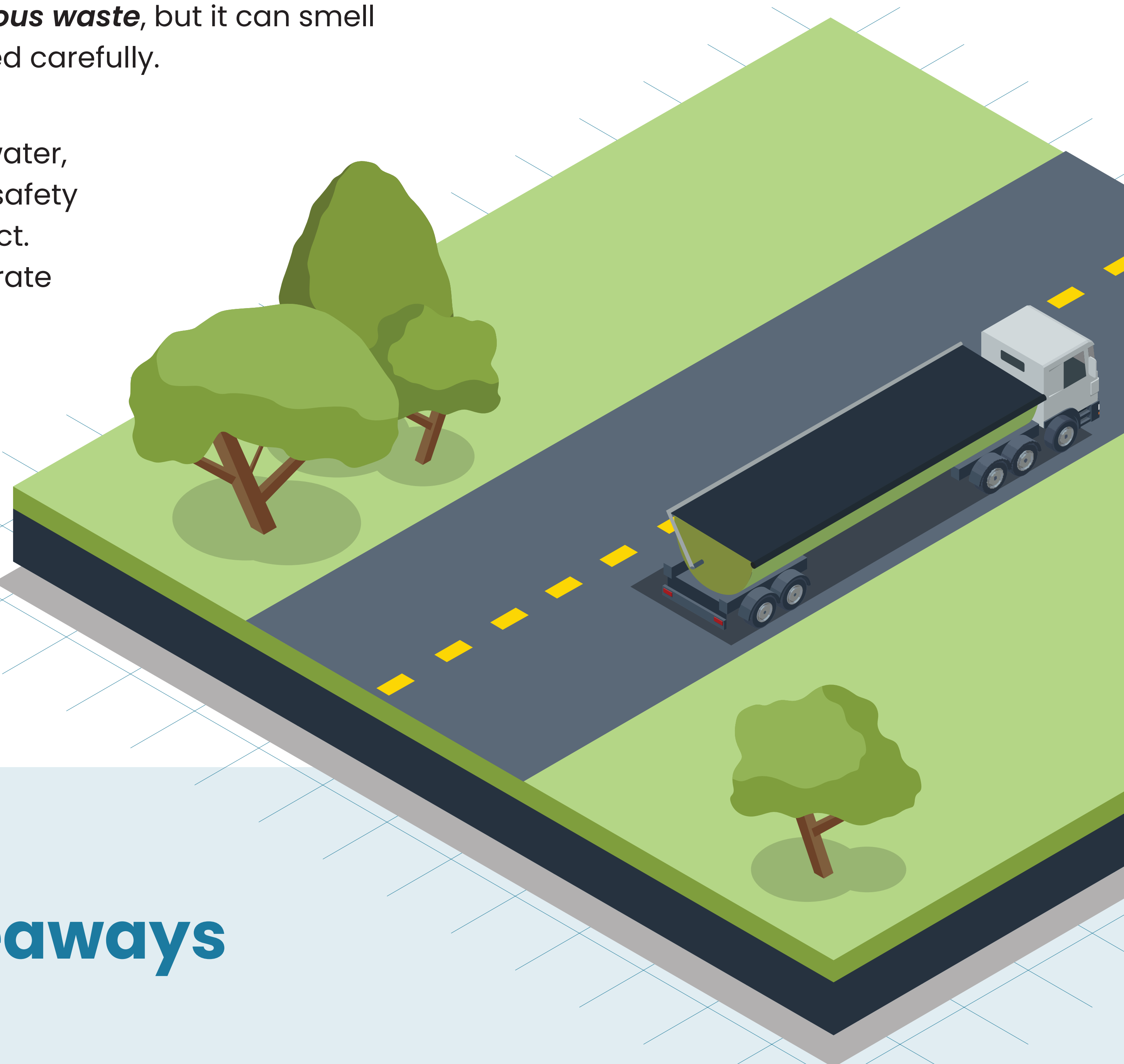

## Key takeaways

**This is a pilot project.** Not all the wet cake at the AltEn site will be removed during this phase. We will learn and apply best practices from this work to inform future decisions.

Materials removed from the AltEn site, including wet cake, are **non-hazardous**.

**Up to six trucks per hour** will transport wet cake each weekday from 6 a.m. to 4:30 p.m. with some variability depending on data, what we learn and the weather.



For more information, please visit [alteninfo.com](http://alteninfo.com)

NDEE has two online sites with information about the AltEn site situation:

1. NDEE public information portal - <http://dee.ne.gov/Press.nsf/pages/AltEn>

2. NDEE public records - <https://ecmp.nebraska.gov/publicaccess/index.html?MyQueryID=340>  
Enter "84069" in the "DEQ Facility Number" field to access AltEn records

## Stormwater management

- A berm will be placed around the work zone to contain stormwater runoff
- Two stormwater collection sumps will capture stormwater and automated pumps will convey the stormwater to the Northeast or Southeast Lagoon for treatment

## Odor and dust mitigation

- Remember, the wet cake is a non-hazardous waste, but it can smell and create dust if not managed carefully
- To manage odor and dust, we are doing the following: Access roads, wet cake piles and stockpiles will be sprayed with water to control visible dust, as necessary
- Exposed wet cake and solidified material stockpiles will be covered with an odor suppressant at the end of each day
- Solidified wet cake will be placed into trucks that are lined with plastic; plastic will also be wrapped and taped over the top of the wet cake to reduce dust and odor during transportation

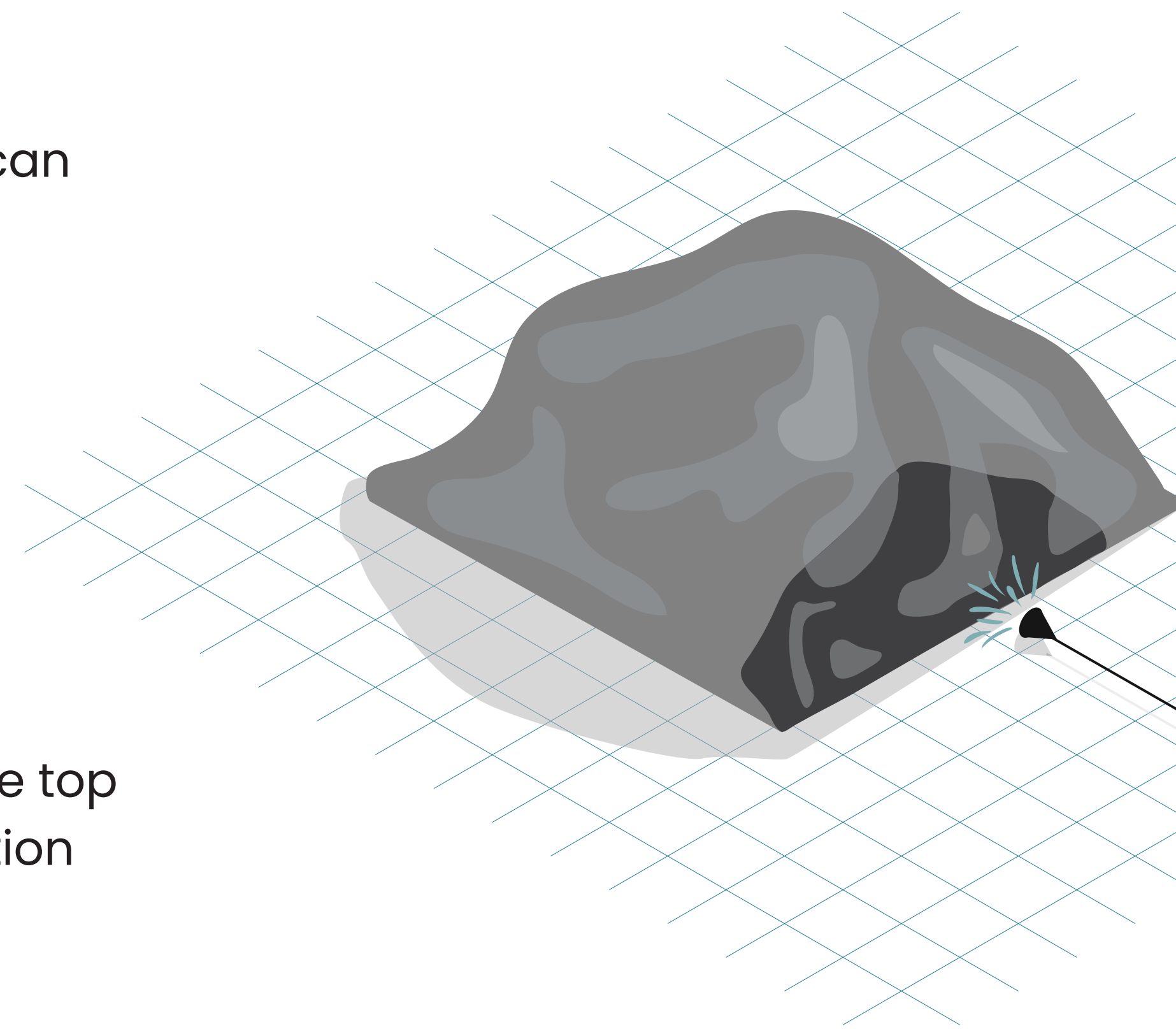
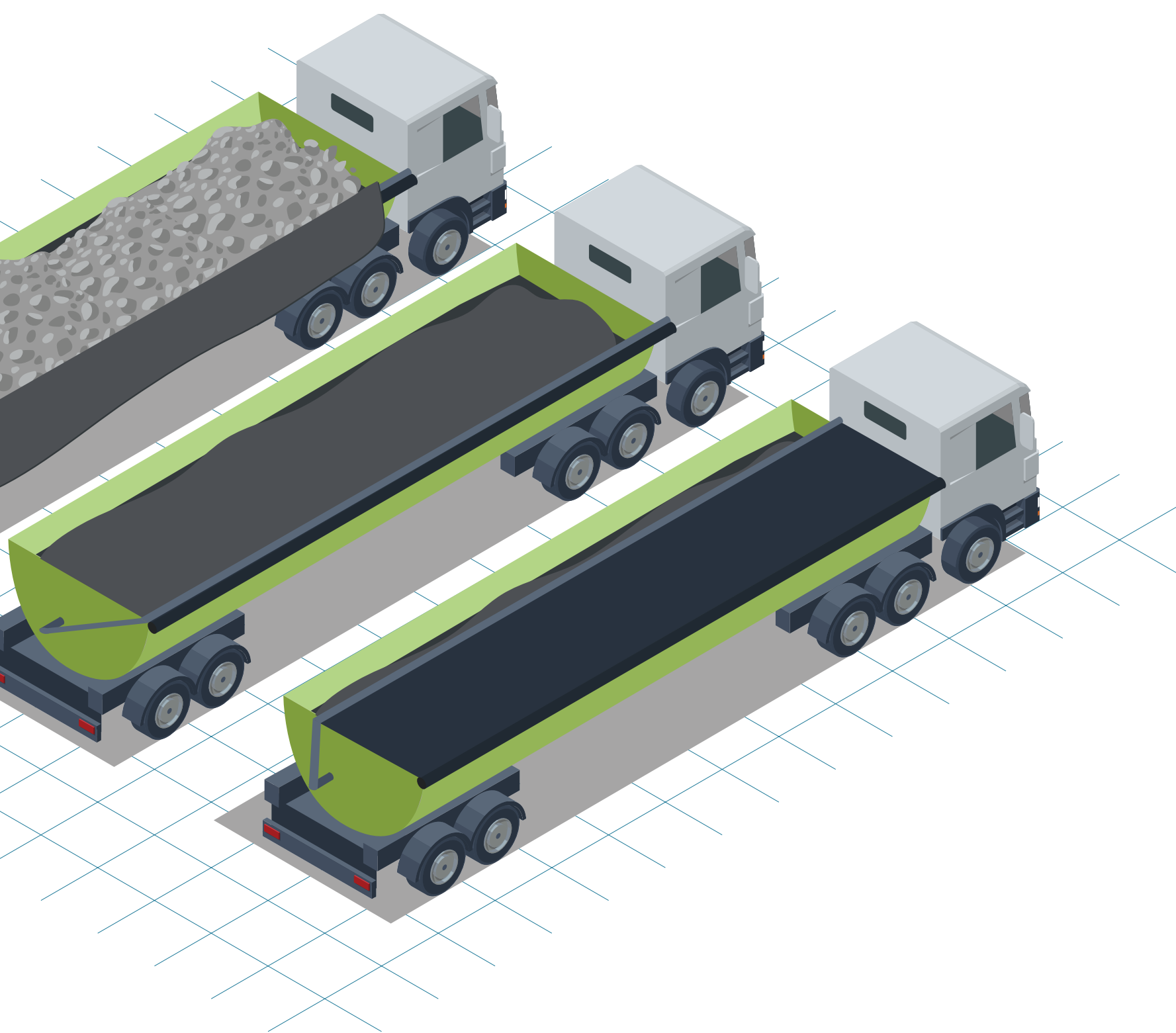

## Air monitoring

- Air monitoring units have been set up around the work zone to continuously monitor air quality along the site perimeter
- Air quality criteria are being developed and will be reviewed by NDEE

## Maintaining clean roads

- Truck tires will be washed prior to exiting the site using an automated tire-washing unit
- County Road 10 will be cleaned daily to remove soil and debris, if any are present

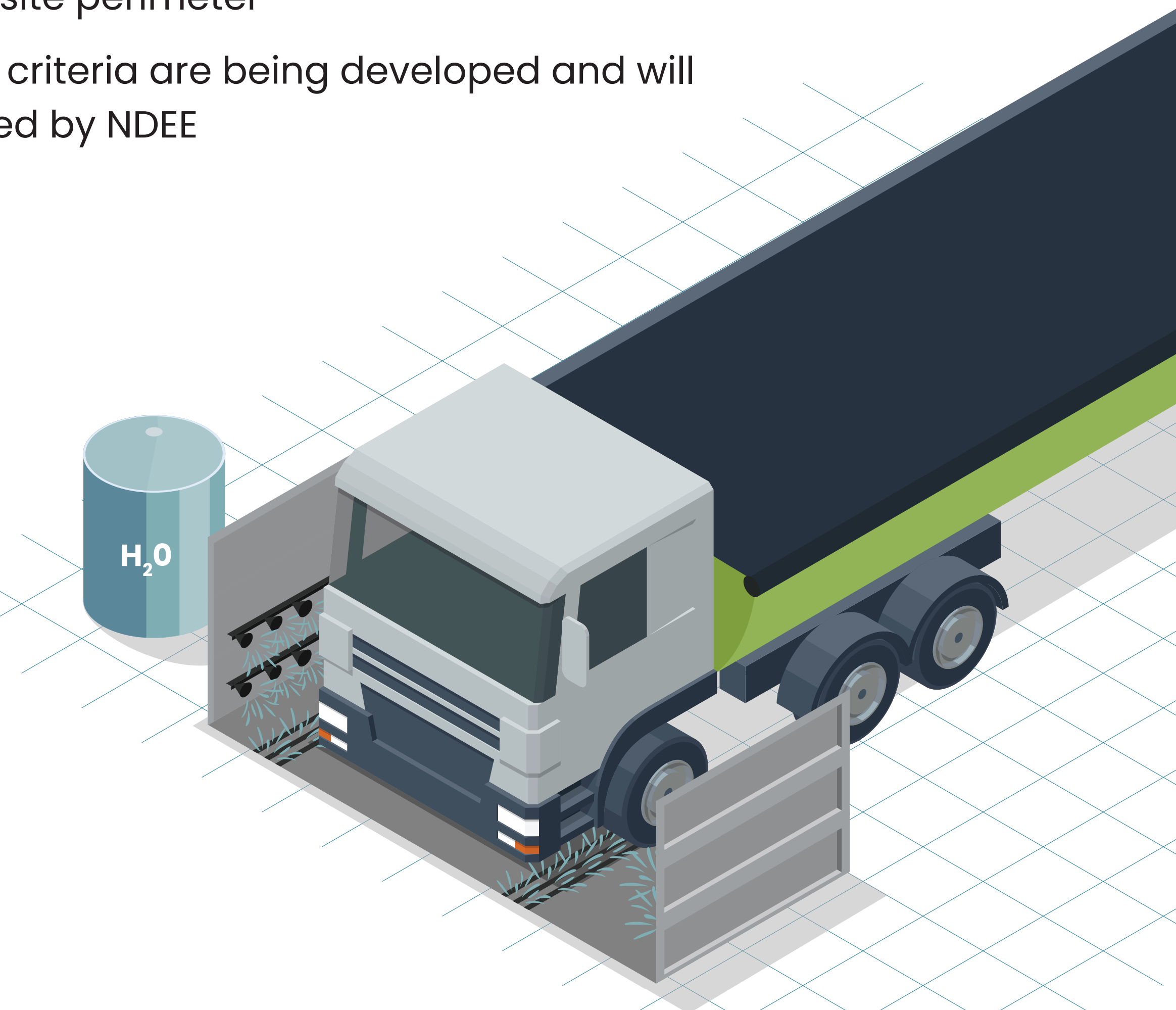

For more information, please visit [alteninfo.com](http://alteninfo.com)

**NDEE has two online sites with information about the AltEn site situation:**

1. NDEE public information portal - <http://dee.ne.gov/Press.nsf/pages/AltEn>

2. NDEE public records - <https://ecmp.nebraska.gov/publicaccess/index.html?MyQueryID=340>  
Enter "84069" in the "DEQ Facility Number" field to access AltEn records